

Valworx 5818 series On/Off Electric Actuators

Valworx electric actuators are 100% tested to ensure trouble free installation and operation.



| PROBLEM | POSSIBLE CAUSE | SOLUTION |
|---|--|---|
| Actuator will not open or close during initial startup | <ul style="list-style-type: none"> • Incorrect wiring | <ul style="list-style-type: none"> • Correct the wiring per actuator electrical diagram and instructions. |
| | <ul style="list-style-type: none"> • No suitable switching device | <ul style="list-style-type: none"> • Customer to supply a mechanical relay or a 3-way 2 or 3 position manual switch to open and close the actuator. |
| | <ul style="list-style-type: none"> • Incorrect voltage being supplied to actuator | <ul style="list-style-type: none"> • Confirm correct voltage is being applied to the actuator. Connecting incorrect voltage may damage the actuator beyond repair. Do not apply more than 25.2 volts to the DC24 volt actuators (24volts +5%). |
| | <ul style="list-style-type: none"> • Undersized power supply | <ul style="list-style-type: none"> • This is a motor circuit, therefore power supply should be sized at least 3 times full load current. |
| | <ul style="list-style-type: none"> • Actuator does not have an isolated circuit or is connected in parallel with other actuators or equipment | <ul style="list-style-type: none"> • Actuator should have its own fused and isolated circuit. Do not connect actuators in parallel or with other equipment on the same circuit. |
| | <ul style="list-style-type: none"> • Controls or controller is not compatible with the actuator | <ul style="list-style-type: none"> • If possible, bench test the actuator without user controls or controller. This will help determine whether there is a problem with the actuator the input control circuit. |
| Actuator (valve) will open, but will not close during initial startup | <ul style="list-style-type: none"> • Incorrect wiring | <ul style="list-style-type: none"> • Check the main power wiring, relay or 3-way switch |
| Actuator will not power up | <ul style="list-style-type: none"> • Excessive power surge and/or an over voltage condition. | <ul style="list-style-type: none"> • Power surges and/or over voltage conditions may damage the actuator beyond repair. |
| | <ul style="list-style-type: none"> • Voltage is too high or too low, out of tolerance range. | <ul style="list-style-type: none"> • Confirm correct voltage is being applied. |
| Actuator stops mid-stroke | <ul style="list-style-type: none"> • Over-torque (possible valve jam). | <ul style="list-style-type: none"> • Remove over-torque condition and retry after overload protection cools down. |
| Cannot turn the manual override knob | <ul style="list-style-type: none"> • Valve jam caused by the fluid media, potential solids or contamination in the media. | <ul style="list-style-type: none"> • Clear valve jam if any and retry unit. If unable to find cause of fault, de-energize and un-bolt actuator from valve. Test both components separately and manually, to ensure each move freely. |
| | <ul style="list-style-type: none"> • Damaged gear drive and/or motor. | <ul style="list-style-type: none"> • Remove actuator from valve and try again, if no change, replace with new actuator or return for evaluation for potential repair. |

Valworx 5818 series On/Off Electric Actuators

| PROBLEM | POSSIBLE CAUSE | SOLUTION |
|--|---|---|
| Actuator fails to operate and condensation or water is found inside the actuator | <ul style="list-style-type: none"> Water intrusion thru electrical conduit and/or connections. | <ul style="list-style-type: none"> Inspect and repair electrical connection. Seal electrical threads. Loop conduit below terminal connection to prevent condensation inside conduit from getting inside actuator. If the actuator has failed due to excessive condensation or water inside the actuator, damage may require replacement with a new actuator or return to factory for evaluation. |
| | <ul style="list-style-type: none"> The visual position indicator's sight glass should never be removed (see image below) | <ul style="list-style-type: none"> If removed, the actuator can no longer be considered explosion proof, discard unit. |
| | <ul style="list-style-type: none"> Built in heater was not activated continuously | <ul style="list-style-type: none"> Power should be maintained ON, either in the open or closed position to activate internal heater. This heater will help prevent condensation buildup inside the actuator. |
| No output signal from position confirmation limit switches | <ul style="list-style-type: none"> Switches are wired incorrectly | <ul style="list-style-type: none"> Correct the wiring problem, reference electrical diagram and instructions. If switches are wired correctly, check for continuity. You should have continuity on closed circuit when actuator is in closed position and continuity on open circuit when actuator is in open position. No continuity when actuator is in between closed and open positions. |
| | <ul style="list-style-type: none"> Exceeding the current capacity has damaged the limit switches. Switch rating 3 amps @ 125/250VAC, 30VDC resistive load. | <ul style="list-style-type: none"> If switches are damaged, return actuator to the factory for evaluation and possible repair or replace with new actuator. |
| | <ul style="list-style-type: none"> Limit switch cams are out of adjustment. | <ul style="list-style-type: none"> If wiring is correct and limit switches are working, cams may need adjusting. Contact customer service for Service Procedure. |



Yellow visual position indicator and cam cover



Sight glass should never be removed



Terminal box cover



Manual override with hex wrench shown

Electrical Wiring Diagram for 5818 series On-Off Actuators



Before connecting power, confirm correct VOLTAGE is being applied. Incorrect voltage may damage actuator and void the warranty.

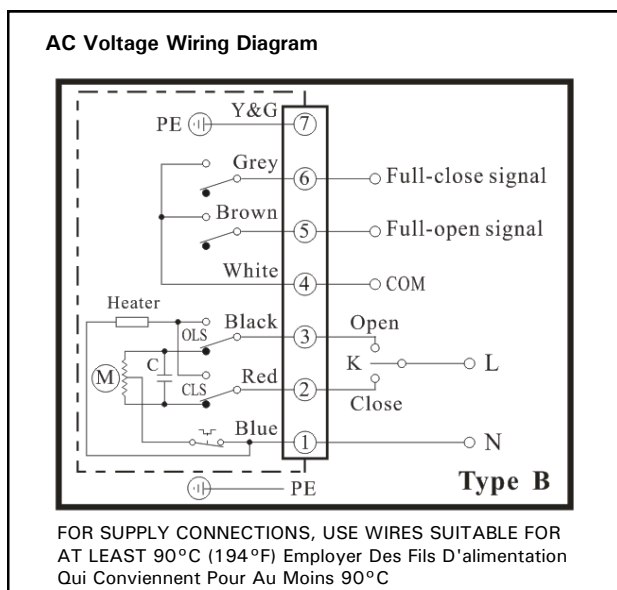

AC Voltage Wiring:

[User/Installer to Supply Relay or 3-way Switch (K)]

Terminal 1: Power Neutral (N)

Terminal 2: Power (L) to terminal 2 - Actuator OFF or CLOSED

Terminal 3: Power (L) to terminal 3 - Actuator ON or OPEN

Auxiliary Position Confirmation Limit Switches

Terminal 4: Common

Terminal 5: Open status confirmation signal

Terminal 6: Closed status confirmation signal

Ground PE

Terminal 7: Earth Ground

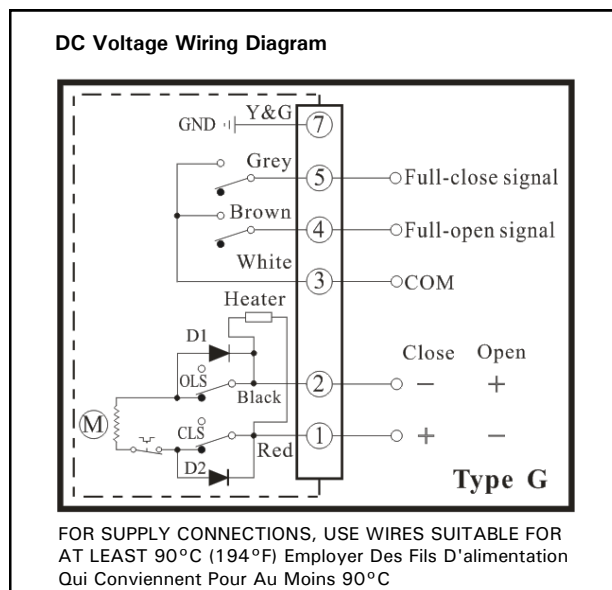

DC Voltage Wiring:

[User/Installer to Supply Reversing Relay or Switch]

Terminal 1: Power Positive (+) to close, power Negative (-) to open

Terminal 2: Power Negative (-) to close, power Positive (+) to open

Auxiliary Position Confirmation Limit Switches

Terminal 3: Common

Terminal 4: Open status confirmation signal

Terminal 5: Closed status confirmation signal

Ground PE

Terminal 7: Earth Ground

NOTES:

1. Auxiliary limit switches are rated 3A@125/250VAC, 30VDC resistive load.
2. Actuator should have its own fused and isolated circuit. Do not wire actuators in parallel or in a circuit with other equipment.
3. Voltage tolerance: 120VAC +/-10%, 24VDC +/-5%

Valve Misapplication

Sometimes electric actuated valves may fail due to misapplication or using the valve in the wrong application. Reviewing and complying with the product specifications will ensure long-term trouble free operation. Specifications can be found online or in the product data sheet. Customers that continue to have problems with an actuator will usually indicate one of two things. Either the actuated valve is unsuitable for the application or it's not in compliance with one or more of the following issues:



Voltage: The voltage must be within the operating range of the actuator. Over voltage or under voltage may cause premature failure.



Temperature: Operating outside the temperature rating will shorten the life and ultimately cause the actuator to fail. Valworx 5618 series actuators must operate within the range of -13 to +131°F (-25 to +55°C).



Environment: The 5818 series actuators have a Type 4X and IP67 weatherproof rating, and various explosion proof approvals. Generally suitable for indoor or outdoor applications. Provides a degree of protection against rain, splashing water and hose directed water (Do not pressure wash). Protecting the actuator against rain, snow, ice and UV (sunlight) will typically extend the life of the product. Highly corrosive environments may cause premature failure of electronic components. Do not use these actuators where explosion proof equipment is required.



Duty Cycle: Exceeding the 70% duty cycle rating of the 5618 series actuators will cause premature failure of the motor, gear drive and/or electronic modules. The motor can run 70% of the time (or typically run for 42 seconds of each minute, must be off for 18 seconds).



Fluid Media: The valve materials of construction should be compatible with the media (fluid) flowing through the valve. This would include all wetted parts or parts in contact with the media. Contacting the manufacturer of the fluid or consulting a media compatibility guide may be helpful. Ball valves and butterfly valves generally require good clean flowing media.



Pressure: Valves must operate within the pressure rating as listed in the specifications. The pressure rating is typically the highest non-shock working pressure allowed within certain temperature limits. Reference the P/T chart (pressure/temperature chart) to confirm the valve will operate within the required pressure and temperature limits.



Fluid Velocity: The fluid velocity should not exceed certain limits to help avoid excessive noise, shock and damage to the piping system, seals and valves. Typically, the maximum velocity of the fluid flowing through Valworx metal valves should be less than 10 feet/second (3 m/s). The maximum velocity for plastic valves should be less than 5 feet/second (1.5 m/s).