

Valworx 5618 series Electric Actuators with EPS Positioner

Valworx electric actuators are 100% tested to ensure trouble free installation and operation.



PROBLEM	POSSIBLE CAUSE	SOLUTION
Actuator will not open or close during initial startup	<ul style="list-style-type: none"> • Incorrect wiring 	<ul style="list-style-type: none"> • Confirm wiring is correct per electrical diagram and instructions.
	<ul style="list-style-type: none"> • Incorrect voltage applied 	<ul style="list-style-type: none"> • Confirm correct voltage is being applied to the actuator. The power on LED should be on when power is applied to the actuator. Do not apply more than 25.2 volts to the DC24 volt actuators (24 volts +5%) or 120 volts to 110 volt actuators (+10%)
	<ul style="list-style-type: none"> • Incorrect control signal input. The signal must be an industry standard analog input control signal. Do NOT connect a battery or variable power supply directly to the control signal input. This will damage the control module. 	<ul style="list-style-type: none"> • Confirm industry standard 4-20mA analog input control signal is being applied to actuator. Malfunction lights may turn on to indicate incorrect inputs (see page 4).
	<ul style="list-style-type: none"> • Undersized power supply 	<ul style="list-style-type: none"> • This is a motor circuit, therefore power supply should be sized at least 3 times full load current.
	<ul style="list-style-type: none"> • Actuator does not have an isolated circuit or is connected in parallel with other actuators or equipment 	<ul style="list-style-type: none"> • Actuator should have its own fused and isolated circuit. Do not connect actuators in parallel or with other equipment on the same circuit.
	<ul style="list-style-type: none"> • Controls or controller is not compatible with the actuator 	<ul style="list-style-type: none"> • If possible, bench test the actuator without user controls or controller. This will help determine whether there is a problem with the actuator or the input control circuit.
Actuator will not power up and/or rotate	<ul style="list-style-type: none"> • Excessive power surge and/or an over voltage condition. 	<ul style="list-style-type: none"> • Power on LED light should be ON when power is applied. If actuator was damaged by a power surge, over voltage condition or improper wiring, replace control module or actuator.
	<ul style="list-style-type: none"> • Voltage is too high or too low, out of tolerance range. 	<ul style="list-style-type: none"> • Confirm correct voltage is being applied.
	<ul style="list-style-type: none"> • Damaged control module 	<ul style="list-style-type: none"> • Replace control module.
	<ul style="list-style-type: none"> • Actuator failure due to exceeding 70% duty cycle rating 	<ul style="list-style-type: none"> • Actuator must be operated within the 70% duty cycle rating. This typically means the motor can run for 42 seconds of each minute and must be OFF for 18 seconds. Continuous modulating will often exceed these limits, if so, add dwell time to your program.
	<ul style="list-style-type: none"> • Loss of control signal 	<ul style="list-style-type: none"> • Find and correct cause of failed control signal, or verify signal at both ends with a meter

Valworx 5618 series Electric Actuators with EPS Positioner

PROBLEM	POSSIBLE CAUSE	SOLUTION
Actuator stops in mid-stroke	<ul style="list-style-type: none"> Over-torque (possible valve jam). 	<ul style="list-style-type: none"> Remove over-torque condition and retry after overload protection cools down If no jam is found, separate actuator from valve and operate manually or electrically to determine which is in fault condition.
	<ul style="list-style-type: none"> Control module or motor/gear failure 	<ul style="list-style-type: none"> Replace with new actuator or return to factory for evaluation
One or more red LED lights is on - wired control module	<ul style="list-style-type: none"> Incorrect control signal input 	<ul style="list-style-type: none"> The signal must be an industry standard 4-20mA analog input control signal. Do NOT connect a battery or variable power supply directly to the control signal input. This will damage the control module.
	<ul style="list-style-type: none"> Control module may require a reset 	<ul style="list-style-type: none"> With actuator powered on, follow the service procedure instructions detailed on page 4.
	<ul style="list-style-type: none"> Actuator exceeding torque limit, and is shutting down to protect the components 	<ul style="list-style-type: none"> Valve jam caused by the fluid media, potential solids or contamination in the media, clear jam and try again.
Cannot turn the manual override	<ul style="list-style-type: none"> Valve jam caused by the fluid media, potential solids or contamination in the media 	<ul style="list-style-type: none"> Clear any valve jams or other issues and try again
	<ul style="list-style-type: none"> Damaged gear drive and/or motor. 	<ul style="list-style-type: none"> Remove actuator from valve and try again, if no change, replace with new actuator
Actuator fails to operate and condensation or water is found inside the actuator	<ul style="list-style-type: none"> Water intrusion thru electrical conduit and/or connections. 	<ul style="list-style-type: none"> Inspect and repair electrical connection. Seal NPT electrical threads. Loop conduit below terminal connection to prevent condensation inside conduit from getting inside actuator. If the actuator has failed due to excessive condensation or water inside the actuator, damage may require replacement with a new actuator or return to factory for evaluation.
	<ul style="list-style-type: none"> Built in heater was not activated continuously 	<ul style="list-style-type: none"> Power should be maintained ON to activate internal heater. This heater will help prevent condensation buildup inside the actuator. If the actuator has failed due to excessive condensation or water inside the actuator, replace actuator or return to factory for evaluation.



Yellow visual position indicator and cam cover



Terminal box cover



Manual override with hex wrench shown

Valworx 5618 series Electric Actuators with EPS Positioner

Valworx electric actuators are 100% tested prior to shipment to ensure trouble free operation.



Before connecting power, confirm correct VOLTAGE is being applied. Incorrect voltage may damage actuator and void the warranty.

AC Voltage Wiring Diagram

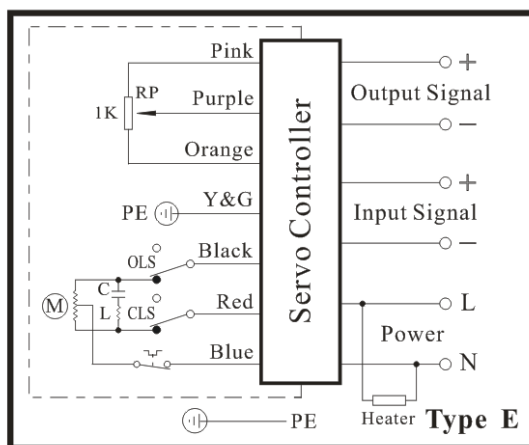

FOR SUPPLY CONNECTIONS, USE WIRES SUITABLE FOR AT LEAST 90°C (194°F) Employer Des Fils D'alimentation Qui Convient Pour Au Moins 90°C

DC Voltage Wiring Diagram

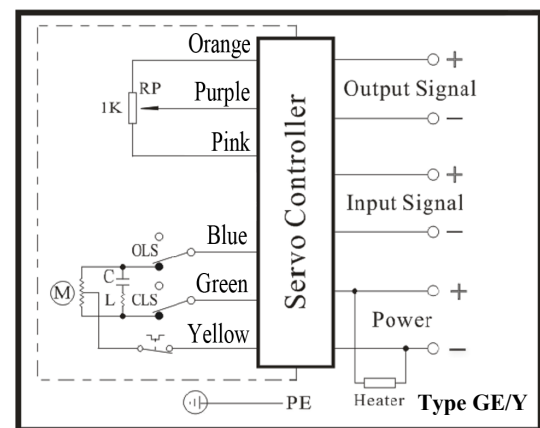

FOR SUPPLY CONNECTIONS, USE WIRES SUITABLE FOR AT LEAST 90°C (194°F) Employer Des Fils D'alimentation Qui Convient Pour Au Moins 90°C

AC Voltage Wiring

- Terminal 1: AC Power Neutral (N)
- Terminal 2: AC Power Line (L)
- Terminal 3: Negative (-) Analog Input control signal
- Terminal 4: Positive (+) Analog Input control signal
- Terminal 5: Negative (-) Output monitoring signal
- Terminal 6: Positive (+) Output monitoring signal
- PE Green/yellow wire: Earth ground

DC Voltage Wiring

- Terminal 1: DC Power Negative (-)
- Terminal 2: DC Power Positive (+)
- Terminal 3: Negative (-) Analog Input control signal
- Terminal 4: Positive (+) Analog Input control signal
- Terminal 5: Negative (-) Output monitoring signal
- Terminal 6: Positive (+) Output monitoring signal
- PE Green/yellow wire: Earth ground

NOTES:

1. Actuator should have its own fused and isolated circuit. Do not wire actuators in parallel or in a circuit with other equipment.
2. Output monitoring signal is in same format as input signal ex: 4-20mA input, 4-20mA output. Use of the output is optional.
3. Voltage tolerance: 110VAC +/-10%, 24VDC +/- 5%

Issue:

In rare cases the open/close positions of an EPS actuator can drift out of calibration, and the actuator will not fully open or close when input control signal is applied. Manual adjustment to factory settings may be necessary. Actuators are 100% tested before shipment.

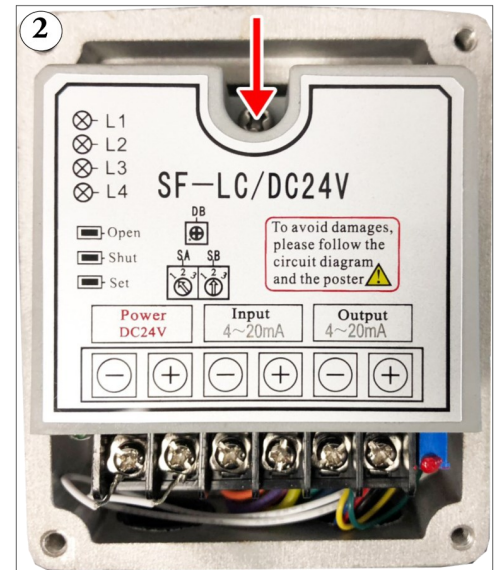

- Loosen all four (non-removable) screws, and remove wiring terminal box cover (image 1).
- Remove single screw holding control module in place (image 2), & carefully raise out of actuator to more easily access adjustment switches.
- Actuator is factory set with White switch **S-A** set to **1** & switch **S-B** set to **2**, respectively "ON" (image 3).
- To adjust position, click both switches so that both arrows for **S-A** & **S-B** point to **2**. This is "Manual" mode (image 3).
- Individually depress marked **black** buttons to adjust positions of actuator. **Top** button controls *Open* positioning and **Bottom** button controls *Closed*. Do **not** over adjust to the point of hitting mechanical stops of actuator. You may verify positioning by indicator and by output drive.
- To set the corresponding final Open or Closed position, depress the horizontal white button - and while continuing to press the white button down, now press the open or closed black button simultaneously - **until** you see the L2 **red** confirmation light come on. Let go of both buttons.
- Your new position should be set (repeat steps 5 & 6 for other position if necessary). When finished, reset switches to original positions, S-A (1) & S-B (2).

Internal Diagram

- Terminal strip
- Selection switches (S-A, S-B)
- L1. Power light (power on - green)
- L2. Control Signal status light (red)
- L3. Potentiometer status light (red)
- L4. Over torque status light (red)
- Manual Open control button
- Manual Close control button
- Set button (white)
- Deadband Adjustment (factory preset)

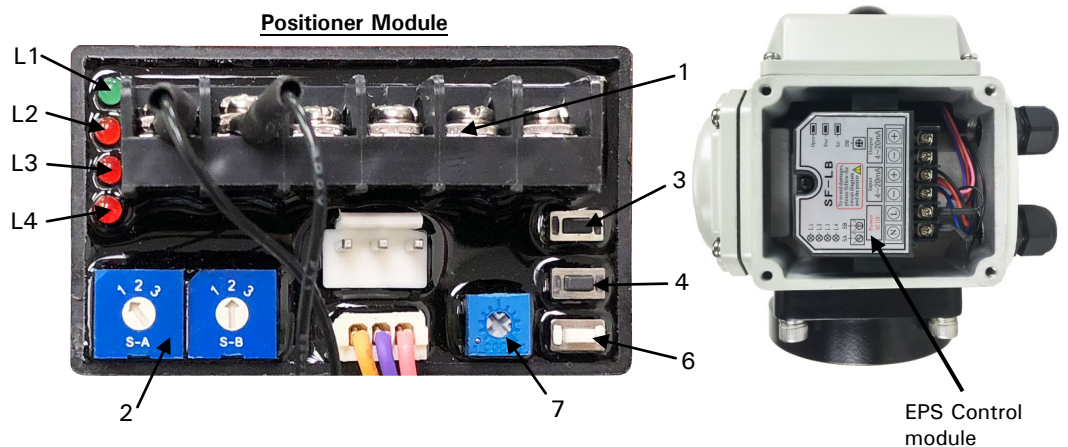

*Note: If any Red LEDs are 'on', there is a malfunction.

Valve Misapplication

Sometimes electric actuated valves may fail due to misapplication or using the valve in the wrong application. Reviewing and complying with the product specifications will ensure long-term trouble free operation. Specifications can be found online or in the product data sheet. Customers that continue to have problems with an actuator will usually indicate one of two things. Either the actuated valve is unsuitable for the application or it's not in compliance with one or more of the following issues:



Voltage: The voltage must be within the operating range of the actuator. Over voltage or under voltage may cause premature failure.



Temperature: Operating outside the temperature rating will shorten the life and ultimately cause the actuator to fail. Valworx 5618 series actuators must operate within the range of -13 to +131°F (-25 to +55°C).



Environment: The 5618 series actuators have a Type 4X and IP67 weatherproof enclosure rating. Generally suitable for indoor or outdoor applications. Provides a degree of protection against rain, splashing water and hose directed water (do not pressure wash). Protecting the actuator against rain, snow, ice and UV (sunlight) will typically extend the life of the product. Highly corrosive environments may cause premature failure of electronic components. Do not use these actuators where explosion proof equipment is required.



Duty Cycle: Exceeding the 70% duty cycle rating of the 5618 series actuators will cause premature failure of the motor, gear drive and/or electronic modules. The motor can run 70% of the time (or typically run for 42 seconds of each minute, off for 18 seconds).



Fluid Media: The valve materials of construction should be compatible with the media (fluid) flowing through the valve. This would include all wetted parts or parts in contact with the media. Contacting the manufacturer of the fluid or consulting a media compatibility guide may be helpful. Ball valves and butterfly valves generally require good clean flowing media.



Pressure: Valves must operate within the pressure rating as listed in the specifications. The pressure rating is typically the highest non-shock working pressure allowed within certain temperature limits. Reference the P/T chart (pressure/temperature chart) to confirm the valve will operate within the required pressure and temperature limits.



Fluid Velocity: The fluid velocity should not exceed certain limits to help avoid excessive noise, shock and damage to the piping system, seals and valves. Typically, the maximum velocity of the fluid flowing through Valworx metal valves should be less than 10 feet/second (3 m/s). The maximum velocity for plastic valves should be less than 5 feet/second (1.5 m/s).