

Valworx 5617 series Electric Actuators with EPS Positioner

Valworx electric actuators are 100% tested to ensure trouble free installation and operation.



PROBLEM	POSSIBLE CAUSE	SOLUTION
Actuator will not open or close during initial startup	<ul style="list-style-type: none"> • Incorrect wiring 	<ul style="list-style-type: none"> • Confirm wiring is correct per electrical diagram and instructions. Internal red LED light will light when there is a fault condition.
	<ul style="list-style-type: none"> • Incorrect voltage applied 	<ul style="list-style-type: none"> • Confirm correct voltage is being applied to the actuator. The internal green LED should be on when power is applied to the actuator. Connecting incorrect voltage may damage the actuator beyond repair. Do not apply more than 25.2 volts to a DC 24 volt actuator (24 volts +/-5%).
	<ul style="list-style-type: none"> • Undersized power supply 	<ul style="list-style-type: none"> • This is a motor circuit, therefore power supply should be sized at least 3 times full load current.
	<ul style="list-style-type: none"> • Incorrect input control signal. 	<ul style="list-style-type: none"> • Input should be an industry standard 4-20mA analog control signal.
	<ul style="list-style-type: none"> • Actuator does not have an isolated circuit or is connected in parallel with other actuators or equipment 	<ul style="list-style-type: none"> • Actuator should have its own fused and isolated circuit. Do not connect actuators in parallel or with other equipment on the same circuit.
	<ul style="list-style-type: none"> • Controls or controller is not compatible with the actuator 	<ul style="list-style-type: none"> • If possible, bench test the actuator without user controls or controller. This will help determine whether there is a problem with the actuator or the input control circuit.
Actuator will not power up and/or rotate	<ul style="list-style-type: none"> • Excessive power surge and/or an over voltage condition. 	<ul style="list-style-type: none"> • Power on green LED light should be ON when power is applied. If actuator was damaged by a power surge, over voltage condition or improper wiring, replace actuator.
	<ul style="list-style-type: none"> • Voltage is to high or to low, out of tolerance range. 	<ul style="list-style-type: none"> • Confirm correct voltage is being applied.
	<ul style="list-style-type: none"> • Damaged control module 	<ul style="list-style-type: none"> • Return actuator to factory for possible repair.
	<ul style="list-style-type: none"> • Actuator failure due to exceeding 60% duty cycle rating 	<ul style="list-style-type: none"> • Actuator must be operated within the 60% duty cycle rating. This typically means the motor can run for 36 seconds of each minute and must be OFF for 24 seconds. Continuous modulating will often exceed these limits, if so, add dwell time to your program.
	<ul style="list-style-type: none"> • Loss of control signal 	<ul style="list-style-type: none"> • Find and correct cause of failed control signal

Valworx 5617 series Electric Actuators with EPS Positioner

PROBLEM	POSSIBLE CAUSE	SOLUTION
Actuator stops in mid-stroke	<ul style="list-style-type: none"> Over-torque (possible valve jam). 	<ul style="list-style-type: none"> Remove over-torque condition and retry after overload protection cools down
	<ul style="list-style-type: none"> Control module or motor/gear failure 	<ul style="list-style-type: none"> Replace with new actuator or return to factory for evaluation
Cannot turn the manual override	<ul style="list-style-type: none"> Valve jam caused by the fluid media, potential solids or contamination in the media 	<ul style="list-style-type: none"> Clear and valve jams to correct issue. De-energize actuator. Separate actuator from valve and test components manually if problem is not clear... they should move freely by hand.
	<ul style="list-style-type: none"> Damaged gear drive and/or motor. 	<ul style="list-style-type: none"> Remove actuator from valve and try again, if no change, replace with new actuator
Actuator fails to operate and condensation or water is found inside the actuator	<ul style="list-style-type: none"> Excessive condensation, loose cover or housing screws, bad gasket seals 	<ul style="list-style-type: none"> If the actuator has failed due to excessive condensation or water inside the actuator, replace actuator. Other actuator options with a built in internal heater may be required If excessive condensation cannot be prevented in your application environment.



Yellow visual position indicator and cam cover



Prewired electrical cable with flying leads



Manual override with hex wrench shown

Electrical Wiring

Valworx electric actuators are 100% tested prior to shipment to ensure trouble free operation.



WARNING: Never connect the main power supply to the input signal or output signal wires. This will damage the actuator beyond repair and is not covered by warranty.



Before connecting power, confirm correct voltage is being applied

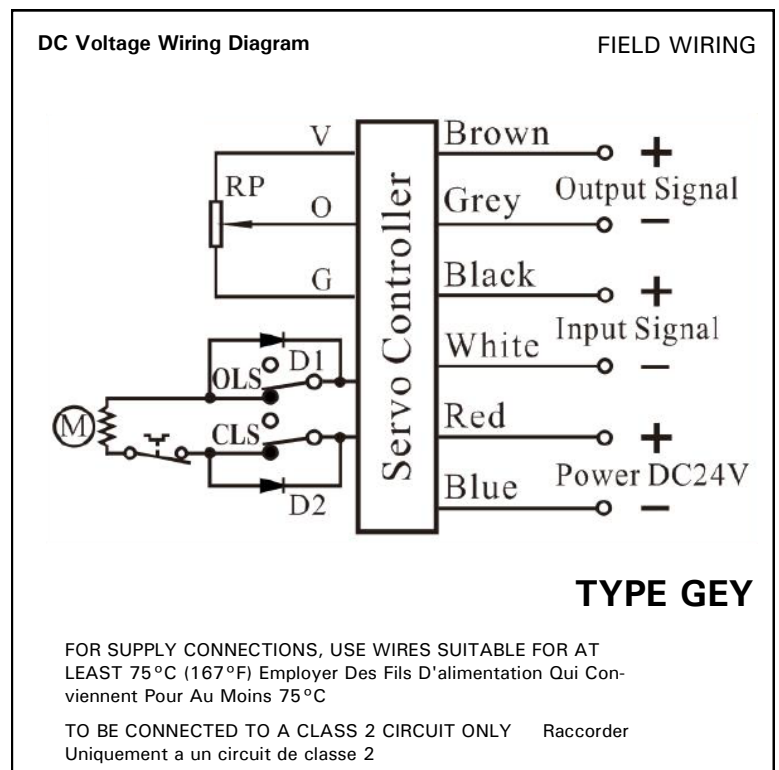
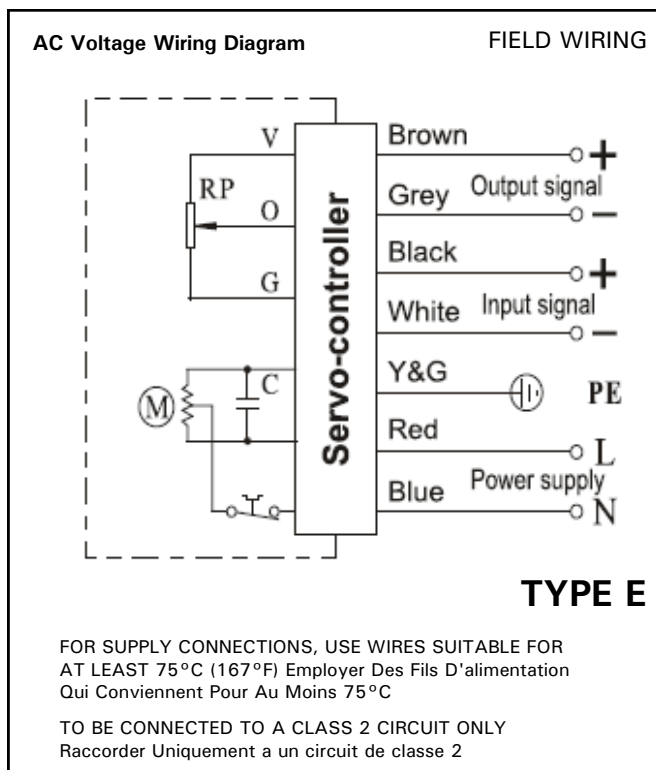

AC Field Wiring:

- BLUE: Power Supply - Neutral (N)
- RED: Power Supply - Line (L)
- WHITE: 4-20mA Input Signal (-)
- BLACK: 4-20mA Input Signal (+)
- GREY: 4-20mA Output Monitoring Signal (-)
- BROWN: 4-20mA Output Monitoring Signal (+)
- YELLOW/GREEN: Earth ground (PE)

DC Field Wiring:

- BLUE: Power Supply - Negative (-)
- RED: Power Supply - Positive (L)
- WHITE: 4-20mA Input Signal (-)
- BLACK: 4-20mA Input Signal (+)
- GREY: 4-20mA Output Monitoring Signal (-)
- BROWN: 4-20mA Output Monitoring Signal (+)
- YELLOW/GREEN: Earth ground (PE)

NOTES:

1. Actuator should have its own fused and isolated circuit. Do not wire actuators in parallel or in a circuit with other equipment.
2. Output monitoring signal is 4-20mA. Use of the output is optional.
3. Voltage tolerance: 110VAC +/-10%, 24DC +/-5%

DIP Switch Setup and Calibration

Valworx electric actuators are 100% tested prior to shipment to ensure trouble free operation.



WARNING: Never connect the main power supply to the input signal or output signal wires. This will damage the actuator beyond repair and is not covered by warranty.



Before connecting power, confirm correct voltage is being applied

LED LIGHTS AND DIP SWITCHES

Lights and dip switches are located under the black top cover of the 5617 series actuators.

LED L1: Green indicator LED L1 lights up when power is applied to the actuator during normal operation.

LED L2: RED indicator LED L2 lights up when there is a fault condition during normal operation. The most common fault condition is the input signal wire is open, shorted or exceeds normal range. The actuator will move to the preset failure mode (open, closed or stop in place) as long as main power is maintained.

SETUP AND CALIBRATION

ALL ACTUATORS ARE CALIBRATED AND TESTED AT THE FACTORY PRIOR TO SHIPMENT. NO ADJUSTMENTS ARE REQUIRED FOR MOST APPLICATIONS. If recalibration is required, contact Valworx for a copy of the setup and calibration instructions.

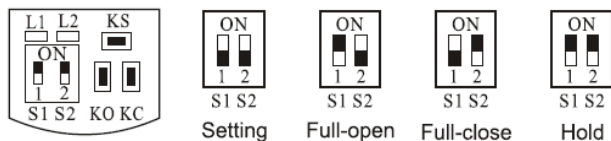

FOR SUPPLY CONNECTIONS, USE WIRES SUITABLE FOR AT LEAST 75°C (167°F) Employer Des Fils D'alimentation Qui Conviennent Pour Au Moins 75°C

TO BE CONNECTED TO A CLASS 2 CIRCUIT ONLY
Raccorder Uniquement a un circuit de classe 2

Dip Switch Setup and Manual Push Button Control			S1	S2
4-20mA Input	Auto Mode S (default setting)	Actuator closed with 4mA signal, open with 20mA signal. Stops with loss of control signal	ON	ON
	Auto Mode C	Actuator closed with 4mA signal, open with 20mA signal. Moves to closed position with loss of control signal	OFF	ON
	Auto Mode O	Actuator closed with 4mA signal, open with 20mA signal. Moves to open position with loss of control signal	ON	OFF
Electrical Manual Operation	Manual Mode - Open	Set S1 and S2 to off and manually move the actuator to open position using push button KC	OFF	OFF
	Manual Mode - Closed	Set S1 and S2 to off and manually move the actuator to closed position using push button KO switches	OFF	OFF

NOTES:

1. Actuator should have its own fused and isolated circuit. Do not wire actuators in parallel or in a circuit with other equipment.
2. Output monitoring signal is 4-20mA. Use of the output is optional.
3. Voltage tolerance: 110VAC +/-10%, 24DC +/-5%

Valve Misapplication

Sometimes electric actuated valves may fail due to misapplication or using the valve in the wrong application. Reviewing and complying with the product specifications will ensure long-term trouble free operation. Specifications can be found online or in the product data sheet. Customers that continue to have problems with an actuator will usually indicate one of two things. Either the actuated valve is unsuitable for the application or it's not in compliance with one or more of the following issues:



Voltage: The voltage must be within the operating range of the actuator. Over voltage or under voltage may cause premature failure.



Temperature: Operating outside the temperature rating will shorten the life and ultimately cause the actuator to fail. Valworx 5617 series actuators must operate within the range of -13 to +131°F (-25 to +55°C).



Environment: The 5617 series actuators have a Type 4X and IP67 weatherproof enclosure rating. Generally suitable for indoor or outdoor applications. Provides a degree of protection against rain, splashing water and hose directed water (do not pressure wash). Protecting the actuator against rain, snow, ice and UV (sunlight) will typically extend the life of the product. Highly corrosive environments may cause premature failure of electronic components. Do not use these actuators where explosion proof equipment is required.



Duty Cycle: Exceeding the 60% duty cycle rating of the 5617 series actuators will cause premature failure of the motor, gear drive and/or electronic modules. The motor can run 60% of the time (or typically run for 36 seconds of each minute, off for 24 seconds).



Fluid Media: The valve materials of construction should be compatible with the media (fluid) flowing through the valve. This would include all wetted parts or parts in contact with the media. Contacting the manufacturer of the fluid or consulting a media compatibility guide may be helpful. Ball valves and butterfly valves generally require good clean flowing media.



Pressure: Valves must operate within the pressure rating as listed in the specifications. The pressure rating is typically the highest non-shock working pressure allowed within certain temperature limits. Reference the P/T chart (pressure/temperature chart) to confirm the valve will operate within the required pressure and temperature limits.



Fluid Velocity: The fluid velocity should not exceed certain limits to help avoid excessive noise, shock and damage to the piping system, seals and valves. Typically, the maximum velocity of the fluid flowing through Valworx metal valves should be less than 10 feet/second (3 m/s). The maximum velocity for plastic valves should be less than 5 feet/second (1.5 m/s).