

## Valworx 5610/5615/5616 series On/Off Electric Actuators

*Valworx electric actuators are 100% tested to ensure trouble free installation and operation.*



5610/5615 Series



5616 Series

PROBLEM	POSSIBLE CAUSE	SOLUTION
Actuator will not open or close during initial startup	<ul style="list-style-type: none"> <li>Incorrect wiring of the gray DIN power connector</li> </ul>	<ul style="list-style-type: none"> <li>Rewiring the gray DIN power plug per the actuator electrical diagram and instructions.</li> </ul>
	<ul style="list-style-type: none"> <li>No suitable switching device</li> </ul>	<ul style="list-style-type: none"> <li>Customer to supply a SPDT mechanical relay or a 3-way 2-position manual switch to open and close the actuator.</li> </ul>
	<ul style="list-style-type: none"> <li>Incorrect voltage being supplied to actuator</li> </ul>	<ul style="list-style-type: none"> <li>Confirm correct voltage is being applied to the actuator. Connecting incorrect voltage may damage the actuator beyond repair. Do not apply more than 25.2 volts to prior model 12-24 volt actuators (24volts +5% tolerance).</li> </ul>
	<ul style="list-style-type: none"> <li>Power supply is not sized large enough</li> </ul>	<ul style="list-style-type: none"> <li>This is a motor circuit, therefore power supply should be sized at least 3 times full load current.</li> </ul>
	<ul style="list-style-type: none"> <li>Actuator does not have an isolated circuit or is connected in parallel with other actuators or equipment</li> </ul>	<ul style="list-style-type: none"> <li>Actuator should have its own fused and isolated circuit. Do not connect actuators in parallel or with other equipment on the same circuit.</li> </ul>
	<ul style="list-style-type: none"> <li>Controls or controller is not compatible with the actuator. Leakage current from solid state relays or contacts may cause actuator malfunction.</li> </ul>	<ul style="list-style-type: none"> <li>If possible, bench test the actuator without user controls or controller. This will help determine whether there is a problem with the actuator or the input control circuit.</li> </ul>
Actuator (valve) will close, but will not open during initial startup. Slow LED blink with DC voltage models.	<ul style="list-style-type: none"> <li>Incorrect wiring of the gray DIN power connector</li> </ul>	<ul style="list-style-type: none"> <li>Neutral or minus (-) power lead <b>MUST</b> be connected to PIN 1 on gray power connector (polarity sensitive).</li> </ul>
Actuator will not power up, LED on top of actuator does not turn ON	<ul style="list-style-type: none"> <li>Excessive power surge and/or an over voltage condition. Damaged main circuit board.</li> </ul>	<ul style="list-style-type: none"> <li>LED light should be ON when power is applied. If actuator was damaged by a power surge or over voltage condition, replace with new actuator, or return for evaluation.</li> </ul>
Actuator LED blinking on-off, red or green (with BSR - battery backup installed)	<ul style="list-style-type: none"> <li>BSR - Battery Spring Return is activated and sending actuator to pre-designated failsafe condition</li> </ul>	<ul style="list-style-type: none"> <li>Restore power to actuator to return to normal operation</li> </ul>
Actuator runs but does not rotate LED double blink or blinking orange	<ul style="list-style-type: none"> <li>Actuator may be in the manual mode</li> </ul>	<ul style="list-style-type: none"> <li>Move "MAN" selector lever to "AUTO"</li> </ul>
Actuator will not complete the cycle LED blinking on-off, red or green	<ul style="list-style-type: none"> <li>Over-torque (possible valve jam).</li> </ul>	<ul style="list-style-type: none"> <li>Remove over-torque condition, repower and try again</li> <li>Remove actuator from valve, test each component separately and manually to confirm which component has caused the fault condition.</li> </ul>
	<ul style="list-style-type: none"> <li>Main control board or motor failure</li> </ul>	<ul style="list-style-type: none"> <li>Replace with new actuator or return to factory for evaluation and/or possible repair.</li> </ul>

PROBLEM	POSSIBLE CAUSE	SOLUTION
Cannot turn the manual override knob	• Manual override selector lever in 'AUTO' mode	• Move manual override selector to 'MAN' mode
	• Excessive force applied to manual override knob, this may have damaged the gear drive	• If after selecting 'MAN', manual override still does not work, replace with a new actuator
	• Valve jam	• Clear valve jam and try again
Actuator fails to operate and condensation or water is found inside the actuator	• DIN plug connectors are loose, missing or have damaged seals. Connector seal installed incorrectly.	• Inspect seals and replace if necessary. Make sure seals are installed correctly and tighten DIN connectors screw securely (0.4 to 0.5Nm).
	• Built in heater was not activated continuously	• Power must be maintained to the actuator either in the open or closed position to activate internal heater. This heater will help prevent condensation buildup inside the actuator. If the actuator has failed due to excessive condensation or water inside the actuator, replace with a new actuator.
Actuator fails and excessive black dust and/or corrosion is found under the red cover	• Excessive condensation or water inside actuator. Highly corrosive environment, saltwater, chemicals, other.	• If the actuator has failed due to excessive black dust or corrosion inside the actuator, typically it is non-repairable and must be replaced with a new actuator.
	• Excessive wear may be caused by exceeding the 75% duty rating of the actuator.	• Actuator must be operated within the 75% duty cycle rating. Typically, this means the motor can be running for 45 seconds, then must be off for 15 seconds of each minute.
	• Actuator is worn out	• Replace with a new actuator
No output signal from position confirmation limit switches	• Switches are wired incorrectly	• Check the switch wiring and make sure the common for limit switches is on PIN 1. If checking continuity, you should have continuity between PIN 1 and 2 when actuator is closed and continuity between PIN 1 and 3 when open. No continuity when actuator is moving in between closed and open positions.
	• Exceeding the current capacity has damaged the limit switch. Switch rating 3 amps @125/250VAC, 30VDC resistive load.	• Damage to the limit switches is not a field repairable item. Either return actuator to the factory for evaluation for potential repair, or replace with a new actuator.
	• Limit switch cams are out of adjustment.	• Limit switch cams can be adjusted if necessary. Contact customer service for Service Procedure.

## Select Indicator Trouble Lights

- Actuator in MANUAL mode (after 3 minute motor timeout) - *Blinking*
- Actuator given open and closed signals simultaneously or power DIN polarity could be wired in reverse - *Continuous*
- Actuator not moving, torque limiter activated while moving from open to closed (or N/C BSR was activated due to power loss) - *Blinking*
- Actuator not moving, torque limiter activated while moving from closed to open (or N/O BSR was activated due to power loss) - *Blinking*
- Actuator not moving after power loss with BSR installed indicates the battery needs recharging - *Blinking*

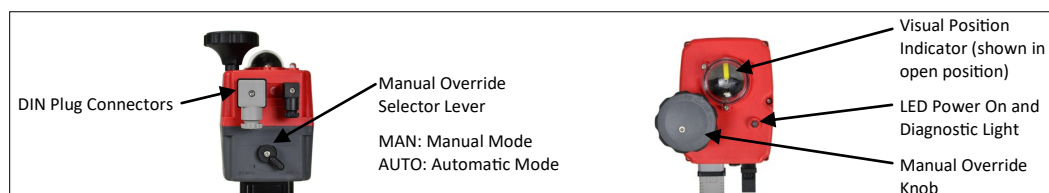

## Electrical Wiring Diagram for 5610/5615/5616 series On-Off Actuators



Before connecting power, confirm correct voltage is being applied

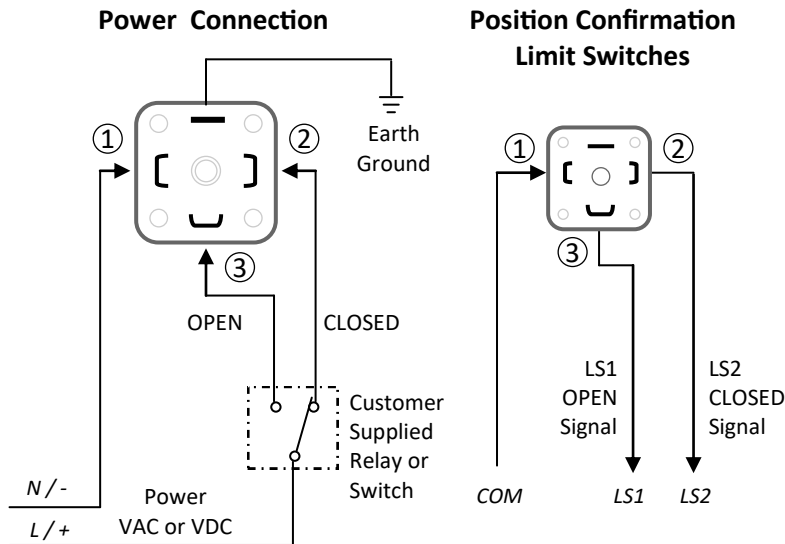

### Wiring Main Power Connection:

Power is connected to the actuator via the large gray DIN plug connector. Wires are connected to screw terminals located inside the connector. User/installer to supply a SPDT mechanical relay or a 3-way 2-position switch to control the actuator open and closed position.

Power supplied to PIN 1 and PIN 2: CLOSED POSITION

Power supplied to PIN 1 and PIN 3: OPEN POSITION

Ground: Connect the flat pin on DIN connector to earth ground

### NOTES:

1. The Neutral (AC voltages) or Negative (DC voltages) must be connected to PIN 1. The actuator is polarity sensitive.
2. Power should be maintained, either in the open or closed position to activate the internal heater. This heater will help prevent condensation build up inside the actuator.
3. Actuator should have it's own fused and isolated circuit. Do not connect actuators in parallel or on the same circuit with other equipment.

Supply voltage to 24 volt actuators should not exceed 25.2 volts (24 volts +5%).

### Wiring Position Confirmation Limit Switches:

Two auxiliary dry contact limit switches are provided to confirm the actuator (valve) open and closed position. Use of these switches is optional and not required for the actuator to function properly. Switch rating 3A@125/250VAC, 30VDC resistive load. Do not connect a ground to this connector.

PIN 1: Common

PIN 2: Output Signal to confirm Closed Position

PIN 3: Output Signal to confirm Open Position

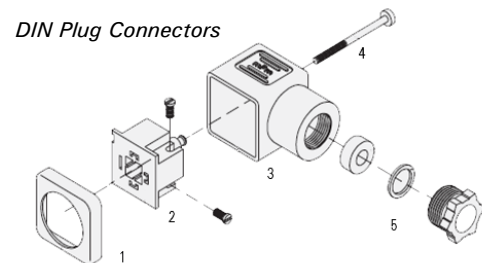

1. Seal
2. Screw terminal block (Pins 1, 2, 3 & G)
3. Connector housing
4. Retainer screw
5. Cable retainer gland

Wire Identification for Optional Prewired DIN Cables	
PIN 1 - Brown	PIN 3 - Black
PIN 2 - Blue	GROUND - Green/Yellow

## Valve Misapplication

Sometimes electric actuated valves may fail due to misapplication or using the valve in the wrong application. Reviewing and complying with the product specifications will ensure long-term trouble free operation. Specifications can be found online or in the product data sheet. Customers that continue to have problems with an actuator will usually indicate one of two things. Either the actuated valve is unsuitable for the application or it's not in compliance with one or more of the following issues:



**Voltage:** The voltage must be within the operating range of the actuator. Over voltage or under voltage may cause premature failure.



**Temperature:** Operating outside the temperature rating will shorten the life and ultimately cause the actuator to fail. Valworx 5610/5615/5616 series actuators must operate within the range of -4 to +158°F (-20 to +70°C).



**Environment:** The 5610/5615/5616 series actuators have an IP67 weatherproof rating. Generally suitable for indoor or outdoor applications. Provides a degree of protection against rain, splashing water and hose directed water (Do not pressure wash). Protecting the actuator against rain, snow, ice and UV (sunlight) will typically extend the life of the product. Highly corrosive environments may cause premature failure of electronic components. Do not use these actuators where explosion proof equipment is required.



**Duty Cycle:** Exceeding the 75% duty cycle rating of the 5610/5615/5616 series actuators will cause premature failure of the motor and/or electronic boards. The motor should not move for at least 25% of the time (or typically 15 seconds of each minute).



**Fluid Media:** The valve materials of construction should be compatible with the media (fluid) flowing through the valve. This would include all wetted parts or parts in contact with the media. Contacting the manufacturer of the fluid or consulting a media compatibility guide may be helpful. Ball valves and butterfly valves generally require good clean flowing media.



**Pressure:** Valves must operate within the pressure rating as listed in the specifications. The pressure rating is typically the highest non-shock working pressure allowed within certain temperature limits. Reference the P/T chart (pressure/temperature chart) to confirm the valve will operate within the required pressure and temperature limits.



**Fluid Velocity:** The fluid velocity should not exceed certain limits to help avoid excessive noise, shock and damage to the piping system, seals and valves. Typically, the maximum velocity of the fluid flowing through Valworx metal valves should be less than 10 feet/second (3 m/s). The maximum velocity for plastic valves should be less than 5 feet/second (1.5 m/s).