

Valworx 5610/5615/5616 series Electric Actuators with Optional DPS Positioner

Valworx electric actuators are 100% tested to ensure trouble free installation and operation.



5610/5616 series



5616 series

PROBLEM	POSSIBLE CAUSE	SOLUTION
Actuator will not open or close during initial startup	<ul style="list-style-type: none"> Incorrect voltage or power connection. 	<ul style="list-style-type: none"> Confirm correct voltage is being applied to gray connector and power connection is wired correctly. Neutral or negative (-) must be connected to PIN 1. Do not apply more than 25.2 volts to prior model 12-24 volt actuators (24volts +5% tolerance).
	<ul style="list-style-type: none"> Incorrect control signal input. This must be an industry standard analog input control signal. Do NOT connect a battery or variable power supply directly to the control signal input. This will damage the control circuit board. 	<ul style="list-style-type: none"> Confirm actuator is setup for correct input (4-20mA or 0-10vdc). Confirm control signal wiring is correct per wiring diagram and instructions
	<ul style="list-style-type: none"> Undersized power supply 	<ul style="list-style-type: none"> This is a motor circuit, therefore power supply should be sized at least 3 times full load current.
	<ul style="list-style-type: none"> Actuator does not have an isolated circuit or is connected in parallel with other actuators or equipment 	<ul style="list-style-type: none"> Actuator should have its own fused and isolated circuit. Do not connect actuators in parallel or with other equipment on the same circuit.
	<ul style="list-style-type: none"> Controls or controller is not compatible with the actuator 	<ul style="list-style-type: none"> If possible, bench test the actuator without user controls or controller. This will help determine whether there is a problem with the actuator or the input control circuit.
Actuator will not power up, LED on top of actuator does not turn ON	<ul style="list-style-type: none"> Excessive power surge and/or an over voltage condition. Damaged circuit board. 	<ul style="list-style-type: none"> LED light should be ON when power is applied. If actuator was damaged by a power surge or over voltage condition, replace with new actuator
Actuator LED blinking on-off, red or green (with BSR - battery backup installed)	<ul style="list-style-type: none"> BSR - Battery Spring Return is activated and sending actuator to pre-designated failsafe condition 	<ul style="list-style-type: none"> Restore power to actuator to return to normal operation
Actuator runs but does not rotate LED double blink or blinking orange	<ul style="list-style-type: none"> Actuator may be in the manual mode 	<ul style="list-style-type: none"> Move "MAN" selector lever to "AUTO"
Actuator will not complete the cycle 5610, 5615 series LED blinking on-off 5616 series LED blinking red or green	<ul style="list-style-type: none"> Over-torque (possible valve jam). 	<ul style="list-style-type: none"> Remove over-torque condition, repower and retry Remove actuator from valve, test each component separately and manually to confirm which component has caused the fault condition.
	<ul style="list-style-type: none"> Main control board or motor failure 	<ul style="list-style-type: none"> Replace with new actuator or return to factory for evaluation and/or possible repair
Actuator powers ON but will not complete cycle	<ul style="list-style-type: none"> Control board or motor failure 	<ul style="list-style-type: none"> Replace with new actuator or return to factory for evaluation.
Cannot turn the manual override knob	<ul style="list-style-type: none"> Manual override selector lever in 'AUTO' mode 	<ul style="list-style-type: none"> Move manual override selector to 'MAN' mode
	<ul style="list-style-type: none"> Excessive force applied to manual override knob, this may have damaged the gear drive 	<ul style="list-style-type: none"> If after selecting 'MAN', manual override still does not work, replace with a new actuator

PROBLEM	POSSIBLE CAUSE	SOLUTION
Actuator fails to operate and condensation or water is found inside the actuator	<ul style="list-style-type: none"> DIN plug connectors are loose, missing or have damaged seals. Connector seals installed incorrectly. 	<ul style="list-style-type: none"> Inspect seals and replace if necessary. Make sure seals are installed correctly and tighten DIN connector screws securely (0.4 to 0.5Nm).
	<ul style="list-style-type: none"> Built in heater was not activated continuously 	<ul style="list-style-type: none"> Power must be maintained 'ON' to activate internal heater. This heater will help prevent condensation buildup inside the actuator. If the actuator has failed due to excessive condensation or water inside the actuator, replace with a new actuator.
Actuator fails and excessive black dust and/or corrosion is found under the red cover	<ul style="list-style-type: none"> Excessive condensation or water inside actuator. Highly corrosive environment, saltwater, chemicals, other. 	<ul style="list-style-type: none"> If the actuator has failed due to excessive black dust or corrosion inside the actuator, typically it is non-repairable and must be replaced with a new actuator.
	<ul style="list-style-type: none"> Excessive wear may be caused by exceeding the 75% duty rating of the actuator. 	<ul style="list-style-type: none"> Actuator must operate within the 75% duty cycle rating. Typically, this means the motor can be running for 45 seconds, then must be off for 15 seconds of each minute.
	<ul style="list-style-type: none"> Actuator could be at end of lifespan 	<ul style="list-style-type: none"> Replace with a new actuator
No output signal from position confirmation limit switches	<ul style="list-style-type: none"> Switches are wired incorrectly 	<ul style="list-style-type: none"> Check the switch wiring and make sure the common for limit switches is on PIN 1. If checking continuity, you should have continuity between PIN 1 and 2 when actuator is closed and continuity between PIN 1 and 3 when open. No continuity when actuator is moving in between closed and open positions.
	<ul style="list-style-type: none"> Exceeding the current capacity has damaged the limit switch. Switch rating 3 amps @ 125/250VAC, 30VDC resistive load. 	<ul style="list-style-type: none"> Damage to the limit switches is not a field repairable item. Either return actuator to the factory for possible repairs or replace with a new actuator.
	<ul style="list-style-type: none"> Limit switch cams are out of adjustment. 	<ul style="list-style-type: none"> Limit switch cams can be adjusted if necessary. Contact customer service for Service Procedure.
Actuator runs but does not rotate LED double blink or blinking orange	<ul style="list-style-type: none"> Actuator may be in the manual mode 	<ul style="list-style-type: none"> Move "MAN" selector lever to "AUTO"
Actuator running through various light sequences (see below)	<ul style="list-style-type: none"> Ensure no wires are connected to Earth Ground on center signal input DIN plug, and signal type matches actuator purchased 	<ul style="list-style-type: none"> Remove wire from Earth Ground, verify correct signal is applied (4-20mA or 0-10V)

Select Indicator Trouble Lights

- DPS reset required - *Alternating Blinking*
- Actuator in MANUAL mode (after 3 minute motor timeout) - *Blinking*
- No control signal found (4-20mA only) - *Blinking* or No control signal found (0-10v only) - *Continuous Light*
- Actuator given open and closed signals simultaneously, or power DIN polarity could be wired in reverse - *Continuous Light*
- Actuator not moving, torque limiter activated while moving from open to closed (or N/C BSR was activated due to power loss) - *Blinking*
- Actuator not moving, torque limiter activated while moving from closed to open (or N/O BSR was activated due to power loss) - *Blinking*
- Battery needs recharging - *Blinking*
- DPS reset could be required. In some cases, this light may alternately indicate incorrect control signal applied (check dip switch settings to match signal type. Return for evaluation if all are verified to be correct. *Alternating Blinking or Continuous Light*



Electrical Wiring Diagram for 5610/5615/5616 Series Actuators with DPS Positioner

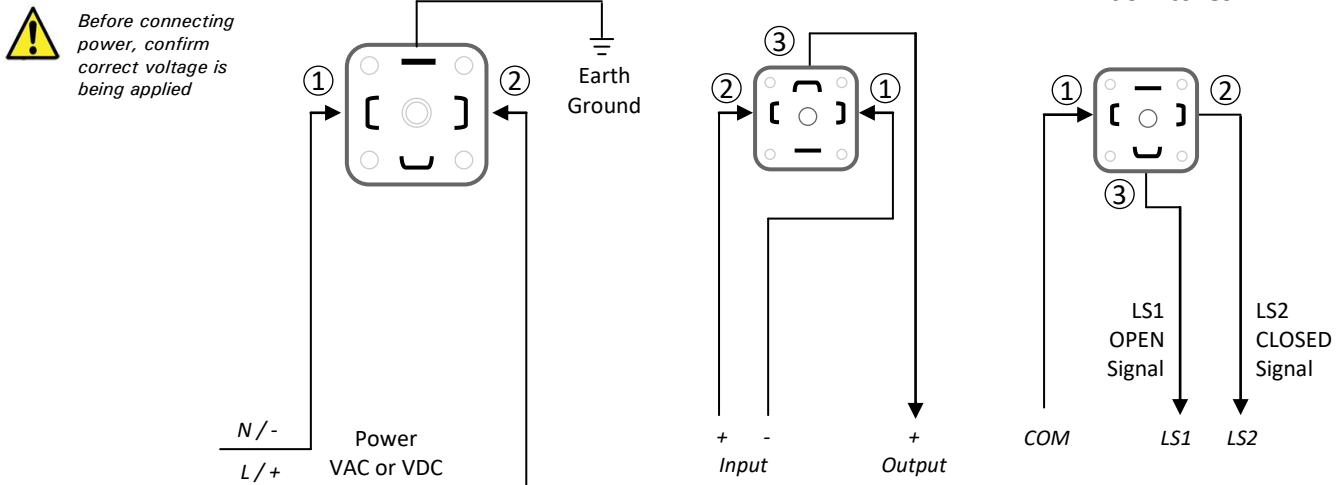

Wiring: Main Power Connection

Power is connected to the actuator via the large gray DIN plug connector. Wires are connected to screw terminals located inside the connector.

Power: connect to PIN 1 and PIN 2

Ground: connect flat pin on DIN connector to earth ground

Notes:

1. The Neutral (AC voltages) or Negative (DC voltages) must be connected to PIN 1.
2. Power should be maintained to activate the internal heater. This heater will help prevent condensation build up inside the actuator.
3. Actuator should have it's own fused and isolated circuit. Do not connect actuators in parallel or on the same circuit with other equipment.
4. Supply voltage to 24 volt actuators should not exceed 25.2 volts (24 volts +5%).

Wiring: Analog Control Signal

Signal Input:

Connect Negative (-) input to PIN 1

Connect Positive (+) input to PIN 2

Signal Output (position monitoring signal):

Connect to PIN 3

Note: The signal output (use of output is optional) will be in the same format as the input. ex: 4-20mA input, 4-20mA output or 0-10v input, 0-10v output. Nominal impedance 100 ohms (4-20mA), 13K ohms (0-10v). Do not connect ground PIN on control signal plug.

DIN Plug Connectors

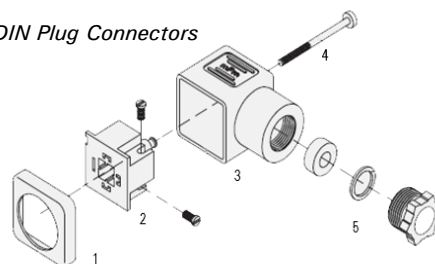

1. Seal
2. Screw terminal block (Pins 1, 2, 3 & G)
3. Connector housing
4. Retainer screw
5. Cable retainer gland

Wiring: Position Confirmation Limit Switches

Two auxiliary dry contact limit switches are provided to confirm the valve open and closed position. Use of these switches is optional. Limit Switch Rating 3A@125/250 VAC, 30VDC resistive load

PIN 1: Common

PIN 2: Signal to confirm Closed Position

PIN 3: Signal to confirm Open Position

Note: Using the position confirmation switches is optional and not required for actuator to function correctly.

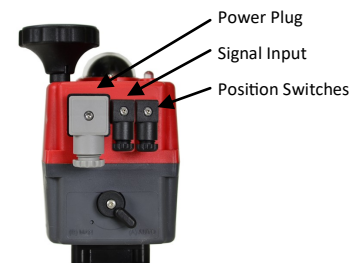

Wiring I.D. for Optional Prewired DIN Cables	
PIN 1 - Brown	PIN 3 - Black
PIN 2 - Blue	GROUND - Green/Yellow

Valve Misapplication

Sometimes electric actuated valves may fail due to misapplication or using the valve in the wrong application. Reviewing and complying with the product specifications will ensure long-term trouble free operation. Specifications can be found online or in the product data sheet. Customers that continue to have problems with an actuator will usually indicate one of two things. Either the actuated valve is unsuitable for the application or it's not in compliance with one or more of the following issues:



Voltage: The voltage must be within the operating range of the actuator. Over voltage or under voltage may cause premature failure.



Temperature: Operating outside the temperature rating will shorten the life and ultimately cause the actuator to fail. Valworx 5610/5615/5616 series actuators must operate within the range of -4 to +158°F (-20 to +70°C).



Environment: The 5610/5615/5616 series actuators have an IP67 weatherproof rating. Generally suitable for indoor or outdoor applications. Provides a degree of protection against rain, splashing water and hose directed water (Do not pressure wash). Protecting the actuator against rain, snow, ice and UV (sun light) will typically extend the life of the product. Highly corrosive environments may cause premature failure of electronic components. Do not use these actuators where explosion proof equipment is required.



Duty Cycle: Exceeding the 75% duty cycle rating of the 5610/5615/5616 series actuators will cause premature failure of the motor and/or electronic boards. This is very important when using the DPS positioner option. The motor should not move for at least 25% of the time (or typically 15 seconds of each minute).



Fluid Media: The valve materials of construction should be compatible with the media (fluid) flowing through the valve. This would include all wetted parts or parts in contact with the media. Contacting the manufacturer of the fluid or consulting a media compatibility guide may be helpful. Ball valves and butterfly valves generally require good clean flowing media.



Pressure: Valves must operate within the pressure rating as listed in the specifications. The pressure rating is typically the highest non-shock working pressure allowed within certain temperature limits. Reference the P/T chart (pressure/temperature chart) to confirm the valve will operate within the required pressure and temperature limits.



Fluid Velocity: The fluid velocity should not exceed certain limits to help avoid excessive noise, shock and damage to the piping system, seals and valves. Typically, the maximum velocity of the fluid flowing through Valworx metal valves should be less than 10 feet/second (3 m/s). The maximum velocity for plastic valves should be less than 5 feet/second (1.5 m/s).